

TEST PROJECT FOR JEWELLERY

WSC2015_TP27_TW_EN

Submitted by:

Name: Mei-Jen Wang

Member: Chinese Taipei /TW





CONTENTS

This Test Project proposal consists of the following documentation:

- WSC2015_TP27_TW_EN.pdf (Text document and Photographs)
- WSC2015_TP27_TW_EN_01.pdf (Technical drawings)

INTRODUCTION

The objective of this test project is that the competitor should complete each of the four modular exercises.

Modules A, B, C and D, consist of the manufacture of jewellery components, which will be marked independently.

Module D also consists of the final assembly of a complete piece of jewellery using all components from the previous Modules.

DESCRIPTION OF PROJECT AND TASKS

Day 1: Before the beginning of Module A the competitor will be given the permitted metal (solders included)

for all exercises, for examination.

- At the beginning of Day 1, the competitor may begin work on all modules.
- At the end of the allotted time for Module A he/she must hand over the completed or uncompleted jewellery component (for marking). Competitors are permitted to start work on remaining modules.
- At the end of Day 1 he/she must hand over all completed or uncompleted jewellery components and all remaining metal (for storage).



Day 2: Before the beginning of Day 2, the competitor will be given the metal remaining from Day 1.

- At the beginning of Day 2, the competitor may begin work on all remaining Modules.
- At the end of the allotted time for Module B he/she must hand over the completed or uncompleted jewellery component (for marking). Competitors are permitted to start work on remaining modules.
- At the end of Day 2 he/she must hand over all completed or uncompleted jewellery components and all remaining metal (for storage).

Day 3: Before the beginning of Day 3, the competitor will be given the metal remaining from Day 2.

- At the beginning of Day 3, the competitor may begin work on all remaining modules.
- At the end of the allotted time for Module C he/she must hand over the completed or uncompleted jewellery component (for marking). Competitors are permitted to start work on remaining modules.
- At the end of Day 3 he/she must hand over all completed or uncompleted jewellery components and all remaining metal (for storage).

Day 4: Before the beginning of Day 4, the competitor will be given the metal remaining from Day 3 and the completed or uncompleted jewellery components for Modules A, B, and C.

- At the beginning of Day 4, the competitor may begin work on Module D with the final assembly.
- At the end of Day 4 he/she must hand over the completed or uncompleted jewellery piece
Of Module D with the final assembly piece (for marking) and all remain metal and filings.

At the end of each day, the components will be labelled by a neutral person and marked. The final result will be the sum of the competitor's marks for all four exercises.



INSTRUCTIONS TO THE COMPETITOR

Competitors will receive the metal for all four modules before the beginning of module A, for verification.

Must use only the metal supplied.

- Competitors must use **only** the metal supplied.
- Competitors must hand in **all** metal at the end of each day.
- Components from modules handed in for marking, may not be returned until the beginning of Day 4.
- Photographs of components may not be taken.

Refer to WSC2015_TD27_EN

EQUIPMENT, MACHINERY, INSTALLATIONS AND MATERIALS REQUIRED

For equipment, machinery and installations refer to section 7 of the Technical Description

(WSC2015_TD27_EN) and Infrastructure List (WSC2015_IL27_EN)



MARKING SCHEME

		MODULE A	MODULE B	MODULE C	MODULE D	TOTA L
A	Similarity to Drawing	5	5	5	5	20
B	Sawing	7	5	0	0	12
C	Soldering	5	4	8	8	25
D	Surface Finish	3	3	5	2	13
E	Dimensions	4	8	5	3	20
F	Completion of Exercise on Time	2	2	3	3	10
Weighting		26	27	26	21	100
Hours		4.5	5.5	6.5	5.5	22

MATERIAL LIST:

1. Yellow gold solder 18 carat (Hard) 1g
2. Yellow gold solder 18 carat (Medium) 1g
3. Yellow gold solder 18 carat (Easy) 1g
4. 18 k Au (y) 3.0 mm round tube (thickness 0,4mm):80mm
5. 18 k Au (y) 2.0mm round wire: 100mm
6. 18 k Au (y) 4.0 mm square wire: 40mm
7. 18 k Au (y) 1.2mm sheet: 40mm x 80mm



■ Photographs



Top view



Back view



Side view



Side view



Back view



Back view

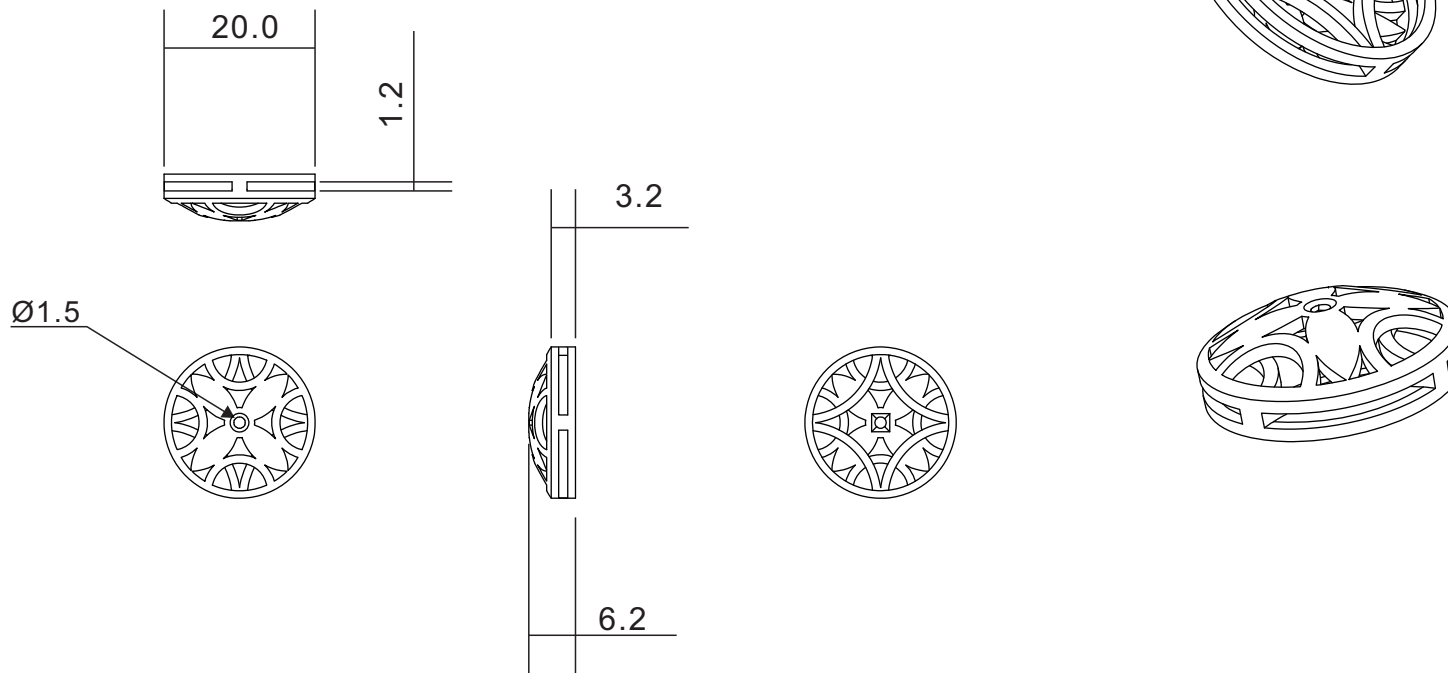

Module A

4.5 Hours



Test Project for the 43rd WorldSkills
Competition in São Paulo, Brazil 2015.
Copyright © 2015 Worldskills International
All Rights Reserved.



Skill: 27-Jewellery			 OR 
Scale: 1:1	Date: 2015	Paper: A4	
Drawn / Design by: Mei-Jen Wang		Drawing No: WSC2015_TP27_TW_01_EN	
Description: 22 Hr Test project		Rev: 1	Page: 1/4

Module B

5.5 Hours

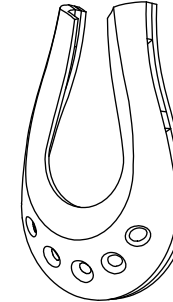
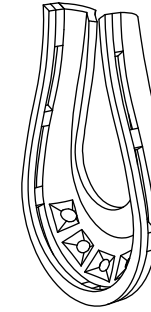
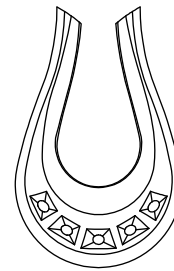
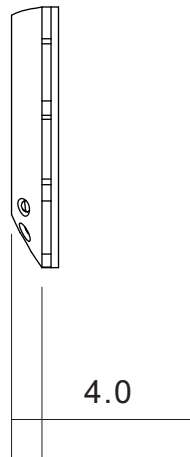
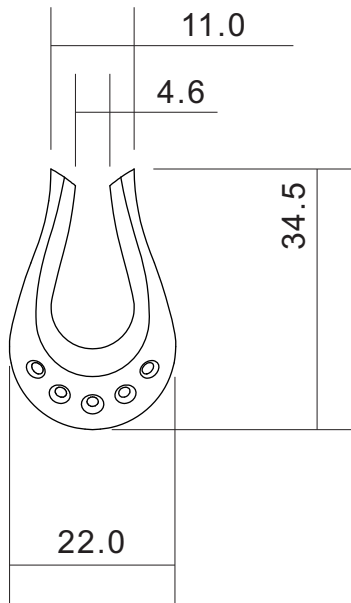
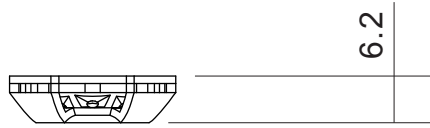

Test Project for the 43rd WorldSkills
Competition in São Paulo, Brazil 2015.
Copyright © 2015 Worldskills International
All Rights Reserved.



Skill: 27-Jewellery

Scale: 1:1 Date: 2015 Paper: A4

Drawn / Design by: Mei-Jen Wang

Description: 22 Hr Test project



Drawing No: WSC2015_TP27_TW_01_EN

Rev: 1

Page: 2/4

Module C

6.5 Hours

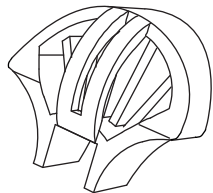
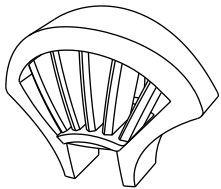
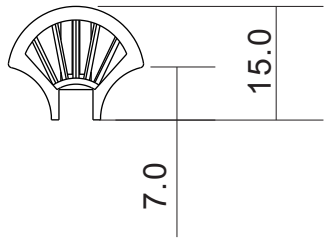
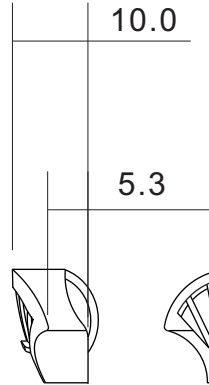
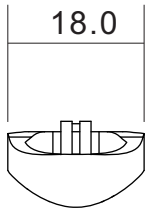

Module D

5.5 Hours

D1

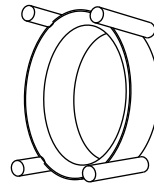
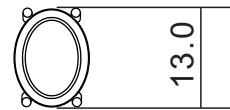
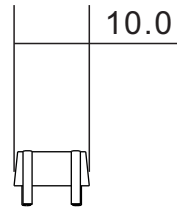

D2

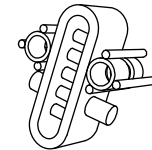
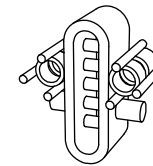
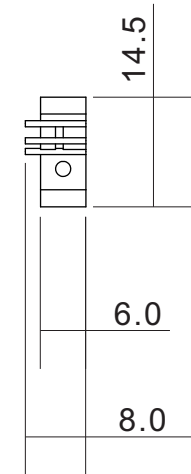
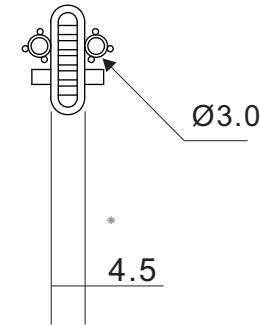
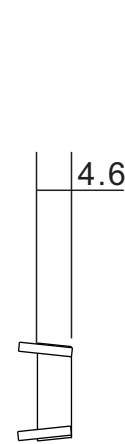
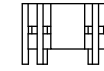

Test Project for the 43rd WorldSkills
Competition in São Paulo, Brazil 2015.
Copyright © 2015 Worldskills International
All Rights Reserved.



Skill: 27-Jewellery

Scale: 1:1 Date: 2015 Paper: A4

Drawn / Design by: Mei-Jen Wang

Description: 22 Hr Test project

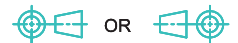

OR



Drawing No: WSC2015_TP27_TW_01_EN

Rev: 1

Page: 3/4

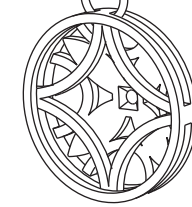
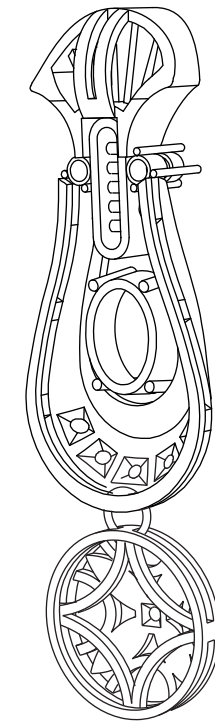
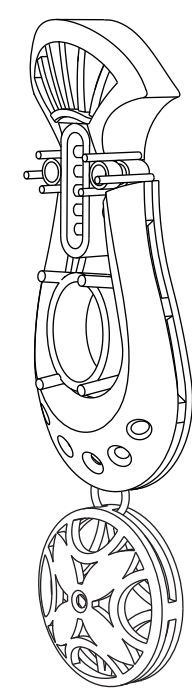
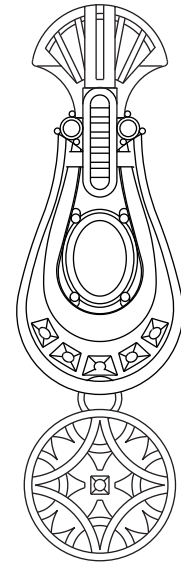
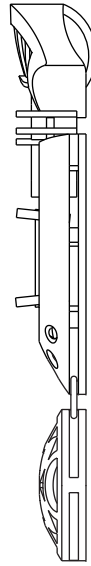
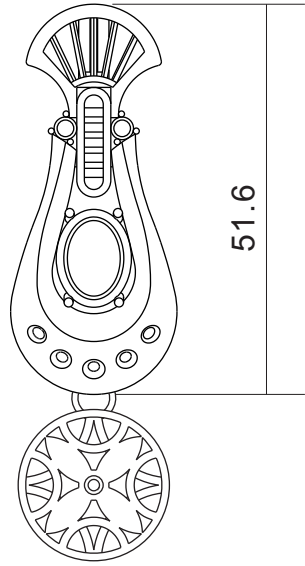
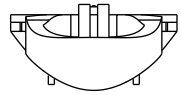

Module A+B+C+D

22Hours



Test Project for the 43rd WorldSkills
Competition in São Paulo , Brazil 2015.
Copyright © 2015 Worldskills International
All Rights Reserved.



Skill: 27-Jewellery			 OR 
Scale: 1:1	Date: 2015	Paper: A4	
Drawn / Design by: Mei-Jen Wang			Drawing No: WSC2015_TP27_TW_01_EN
Description: 22 Hr Test project			Rev: 1 Page: 4/4